

T4 50W 12V GY6.35 950lm

| h(ft) | E(fc) | D |
|-------|-------|-------|
| | | 55° |
| 3 | 75 | 3'1" |
| 6 | 19 | 6'3" |
| 9 | 8 | 9'4" |
| 12 | 5 | 12'6" |
| 15 | 3 | 15'7" |

85025.023 Graphit m
T4 50W 12V GY6.35 950lm

Product description

Cylinder and mounting plate: corrosion-resistant, cast aluminum, No-rinse surface treatment. Double powder-coated.

Electronic transformer 120/12V, 60Hz. 1 cable entry. Through-wiring possible. 3-pole terminal block.

Low brightness reflector: aluminum, silver, specular anodized. Cut-off angle 30° from horizontal. Diffuser as lamp cover: glass, frosted.

Fixing ring with safety glass: corrosion-resistant cast aluminum, double powder-coated. To be removed together with low brightness reflector for lamp replacement. Tamper-proof screw.

Use dimmers for electronic transformers (trailing edge).

Suitable for wet location (IP65): dust-proof and water jet-proof.

Weight 3.42lbs / 1.55kg

Accessories

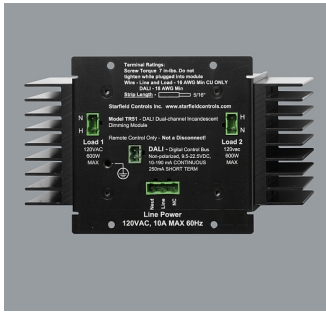

83829.023
 DALI dimmer, double, 10A
 2 load outputs 600W for dimming
 for ohmic loads and electronic
 transformers.
 DALI interface with two independ-
 ent addresses.
 Mains connection 120V, 10A.
 Housing: metal, black.
 LED function indicator. Primary
 fuse.
 Weight 2.29lbs / 1.04kg

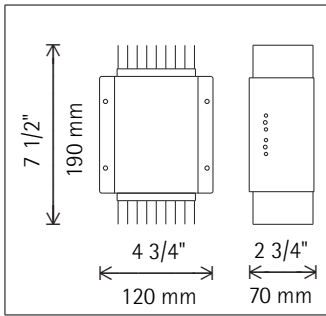

34990.000
 Spacer
 for surface-mounted cables.
 Corrosion-resistant cast aluminum,
 No-Rinse surface treatment.
 Graphit m, double powder-coated.
 Weight 0.35lbs / 0.16kg

